

Write your name here			
Surname		Other names	
Pearson Edexcel		Centre Number	Candidate Number
Level 1/Level 2 GCSE (9 - 1)		<input type="text"/> <input type="text"/> <input type="text"/> <input type="text"/> <input type="text"/>	<input type="text"/> <input type="text"/> <input type="text"/> <input type="text"/>
<h1 style="margin: 0;">Biology</h1>			
<h2 style="margin: 0;">Paper 1</h2>			
Foundation Tier			
Tuesday 15 May 2018 – Afternoon		Paper Reference	
Time: 1 hour 45 minutes		1BI0/1F	
You must have: Calculator, ruler			Total Marks

Instructions

- Use **black** ink or ball-point pen.
- **Fill in the boxes** at the top of this page with your name, centre number and candidate number.
- Answer **all** questions.
- Answer the questions in the spaces provided
– *there may be more space than you need.*
- Calculators may be used.
- Any diagrams may NOT be accurately drawn, unless otherwise indicated.
- You must **show all your working out** with **your answer clearly identified** at the **end of your solution**.

Information

- The total mark for this paper is 100.
- The marks for **each** question are shown in brackets
– *use this as a guide as to how much time to spend on each question.*
- In questions marked with an **asterisk (*)**, marks will be awarded for your ability to structure your answer logically showing how the points that you make are related or follow on from each other where appropriate.

Advice

- Read each question carefully before you start to answer it.
- Try to answer every question.
- Check your answers if you have time at the end.

Turn over ►

P52468A

©2018 Pearson Education Ltd.

1/1/1/1/1/1/1/1/



Pearson

Answer ALL questions. Write your answers in the spaces provided.

Some questions must be answered with a cross in a box ☒.
If you change your mind about an answer, put a line through the box ☒ and then mark your new answer with a cross ☒.

- 1 (a) Pathogens cause disease.

Draw one straight line from each type of pathogen to the disease that is caused by that pathogen.

(2)

type of pathogen	disease
<div style="border: 1px solid black; padding: 5px; width: fit-content; margin: 0 auto;">fungus</div>	<div style="border: 1px solid black; padding: 5px; width: fit-content; margin: 0 auto; text-align: center;">AIDS</div>
<div style="border: 1px solid black; padding: 5px; width: fit-content; margin: 0 auto;">virus</div>	<div style="border: 1px solid black; padding: 5px; width: fit-content; margin: 0 auto; text-align: center;">malaria</div>
	<div style="border: 1px solid black; padding: 5px; width: fit-content; margin: 0 auto; text-align: center;">tuberculosis</div>
	<div style="border: 1px solid black; padding: 5px; width: fit-content; margin: 0 auto; text-align: center;">cholera</div>
	<div style="border: 1px solid black; padding: 5px; width: fit-content; margin: 0 auto; text-align: center;">Chalara ash dieback</div>

- (b) Antibiotics can be used to treat diseases.

Antibiotics kill

(1)

- A antibodies
- B antigens
- C bacteria
- D viruses



(c) Figure 1 shows the number of white blood cells in blood samples from three patients.

	Patient X	Patient Y	Patient Z
Number of white blood cells per μl	8 500	5 700	12 500

Figure 1

Explain why the data suggests that Patient Z has a bacterial infection.

(2)

.....

.....

.....

.....

.....

.....

.....

(d) HIV is diagnosed by blood tests.

State **two** safety precautions that need to be taken when handling blood samples.

(2)

1.....

.....

2.....

.....

.....

(Total for Question 1 = 7 marks)



P 5 2 4 6 8 A 0 3 3 2

2 Figure 2 shows part of a DNA molecule.

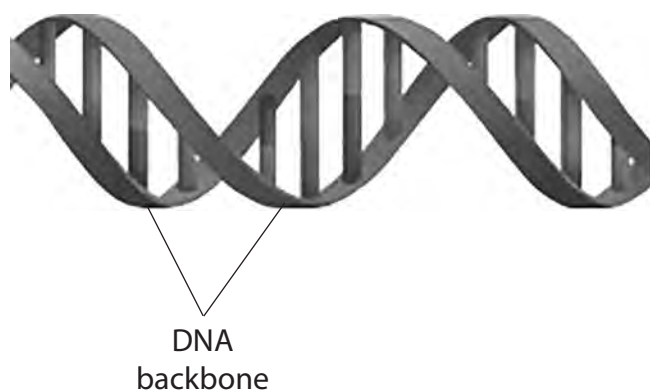

Figure 2

(a) (i) What is the shape of a DNA molecule?

(1)

- A single helix
- B double helix
- C complementary helix
- D triple helix

(ii) Which molecules are present in the DNA backbone?

(1)

- A sugars and phosphates
- B amino acids and bases
- C sugars and bases
- D amino acids and phosphates

(iii) State the type of bond that joins the bases together in the DNA molecule.

(1)

DO NOT WRITE IN THIS AREA

DO NOT WRITE IN THIS AREA

DO NOT WRITE IN THIS AREA

DO NOT WRITE IN THIS AREA

DO NOT WRITE IN THIS AREA

DO NOT WRITE IN THIS AREA



(b) DNA can be extracted from fruit.

Describe how cells are broken down to release DNA.

(2)

.....

.....

.....

.....

(c) In 2003, scientists finished sequencing the 3 billion base pairs in the human genome.

State **two** benefits that the Human Genome Project could have for medicine.

(2)

1

.....

2

.....

(Total for Question 2 = 7 marks)

DO NOT WRITE IN THIS AREA

DO NOT WRITE IN THIS AREA

DO NOT WRITE IN THIS AREA

DO NOT WRITE IN THIS AREA

DO NOT WRITE IN THIS AREA

DO NOT WRITE IN THIS AREA



3 Gregor Mendel investigated genetic inheritance using pea plants.
 Figure 3 shows some of the equipment used in this investigation.

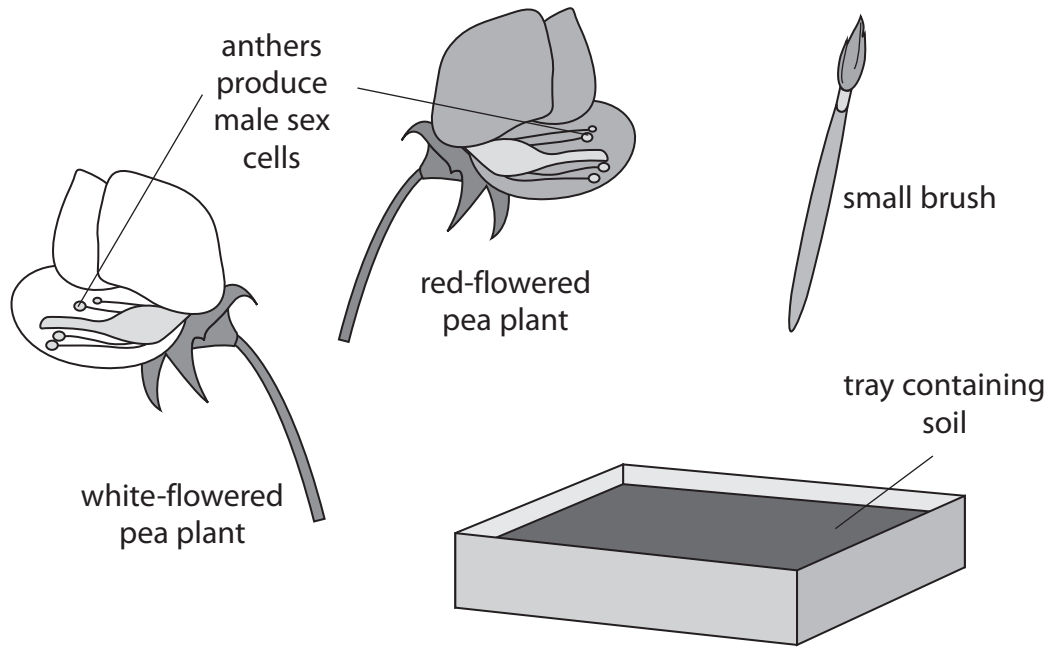

Figure 3

(a) (i) Gregor Mendel crossed red-flowered pea plants with white-flowered pea plants.

Describe how this equipment could be used to do this cross and discover the flower colour of the new pea plants produced.

(3)

.....

.....

.....

.....

.....

.....

(ii) Describe how to make sure that the results obtained from this investigation are not anomalous.

(2)

.....

.....

.....

.....

DO NOT WRITE IN THIS AREA

DO NOT WRITE IN THIS AREA

DO NOT WRITE IN THIS AREA

DO NOT WRITE IN THIS AREA

DO NOT WRITE IN THIS AREA

DO NOT WRITE IN THIS AREA



- (b) In a different investigation, Mendel crossed pea plants that produced yellow seeds (AA) with pea plants that produced green seeds (aa). The dominant allele is shown as A.

The Punnett square shows the genotypes of the offspring from this cross.

	A	A
a	Aa	Aa
a	Aa	Aa

Explain a conclusion that can be made from the results of this cross.

(2)

.....

.....

.....

.....

- (c) Mendel did his investigations in the 19th century.

State **one** reason why Mendel could not fully explain the results of his investigations.

(1)

.....

.....

.....

(Total for Question 3 = 8 marks)



P 5 2 4 6 8 A 0 7 3 2

- 4 Figure 4 shows a picture seen through healthy eyes and the same picture seen through eyes affected by cataracts.



picture seen through healthy eyes



picture seen through eyes with cataracts

Figure 4

- (a) (i) In which part of the eye do cataracts form?

(1)

- A retina
- B iris
- C cornea
- D lens

- (ii) Explain why the picture seen through eyes with cataracts is less clear.

(2)

.....

.....

.....

.....

DO NOT WRITE IN THIS AREA

DO NOT WRITE IN THIS AREA

DO NOT WRITE IN THIS AREA

DO NOT WRITE IN THIS AREA

DO NOT WRITE IN THIS AREA

DO NOT WRITE IN THIS AREA



(b) Figure 5 shows the estimated number of people with cataracts in the world between 1980 and 2020.

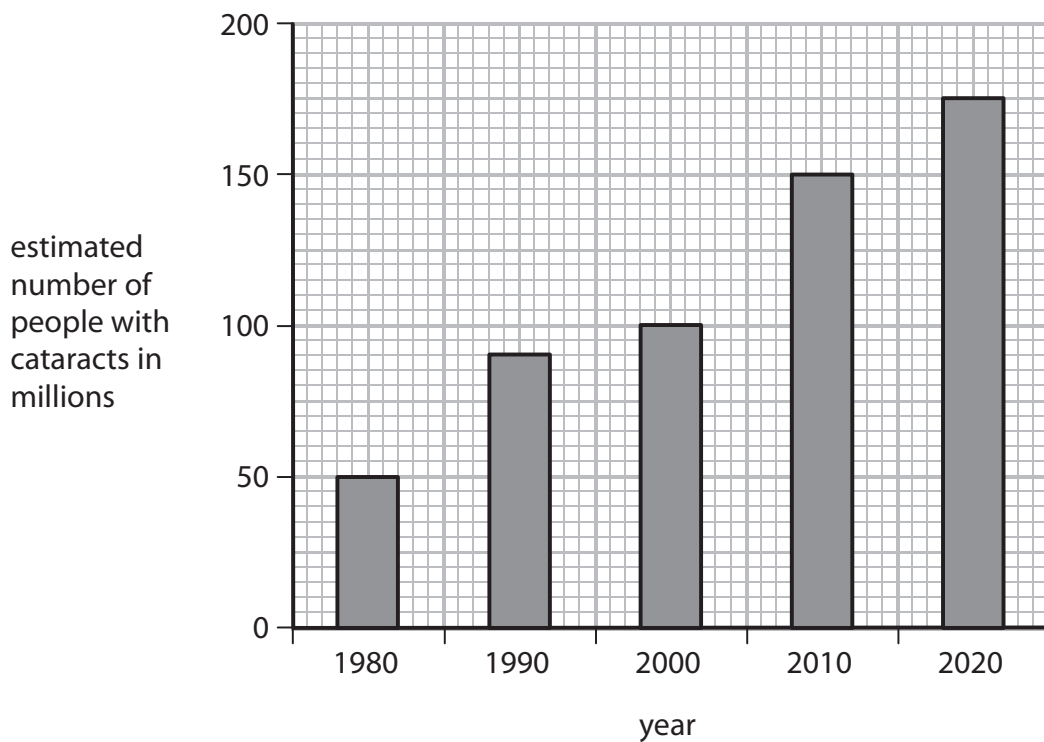

Figure 5

Describe the change in the estimated number of people with cataracts between 1980 and 2020.

(2)

.....

.....

.....

.....





(c) (i) Explain how cataracts are currently treated.

(2)

.....

.....

.....

.....

(ii) Scientists are developing a new treatment using eye drops for cataracts.

Describe the advantages of using eye drops to treat cataracts rather than the current treatment.

(2)

.....

.....

.....

.....

(Total for Question 4 = 9 marks)

DO NOT WRITE IN THIS AREA

DO NOT WRITE IN THIS AREA

DO NOT WRITE IN THIS AREA

DO NOT WRITE IN THIS AREA

DO NOT WRITE IN THIS AREA

DO NOT WRITE IN THIS AREA





DO NOT WRITE IN THIS AREA

DO NOT WRITE IN THIS AREA



BLANK PAGE

DO NOT WRITE IN THIS AREA

DO NOT WRITE IN THIS AREA



P 5 2 4 6 8 A 0 1 1 3 2



- 5 A student investigated the effect of enzyme concentration on the mass of product formed in one hour.

Figure 6 shows the results of this investigation.

concentration of enzyme in arbitrary units	mass of product formed in grams
5	15
10	22
15	25
20	32
25	38
30	40
35	40
40	40

Figure 6

- (a) Complete the graph by plotting the points and drawing a line to show the trend in the data.

The first three points have been plotted for you.

(2)

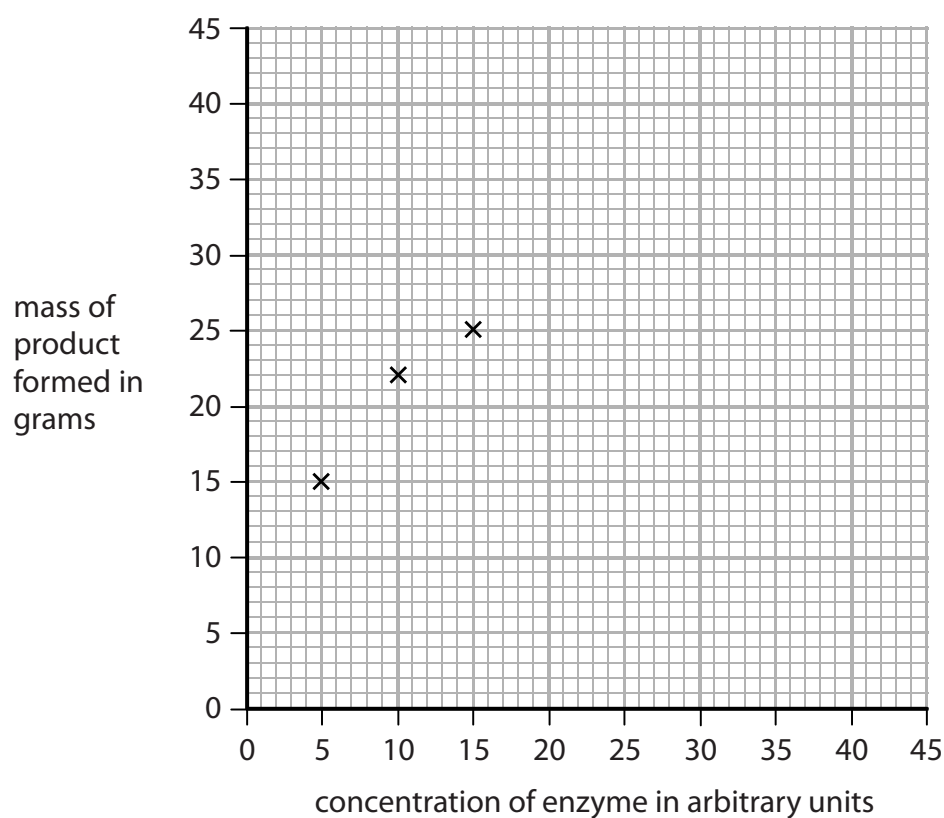

(b) Describe the effect that enzyme concentration has on the mass of product formed.

(2)

.....

.....

.....

(c) The ratio of enzyme concentration to the mass of product formed, using an enzyme concentration of 40 arbitrary units, is 1:1.

Calculate the ratio of enzyme concentration to product formed when the enzyme concentration is 5 arbitrary units.

(2)

ratio.....

(d) The investigation used the enzyme pepsin from the stomach, at a temperature of 37°C and at a pH of 7.

(i) Which statement gives one way to increase the mass of product formed in this investigation?

(1)

- A** increase the pH
- B** decrease the temperature
- C** decrease the enzyme concentration
- D** increase the substrate concentration

(ii) Explain why a temperature of 80°C was not used in this investigation.

(3)

.....

.....

.....

.....

.....

.....

(Total for Question 5 = 10 marks)



P 5 2 4 6 8 A 0 1 3 3 2

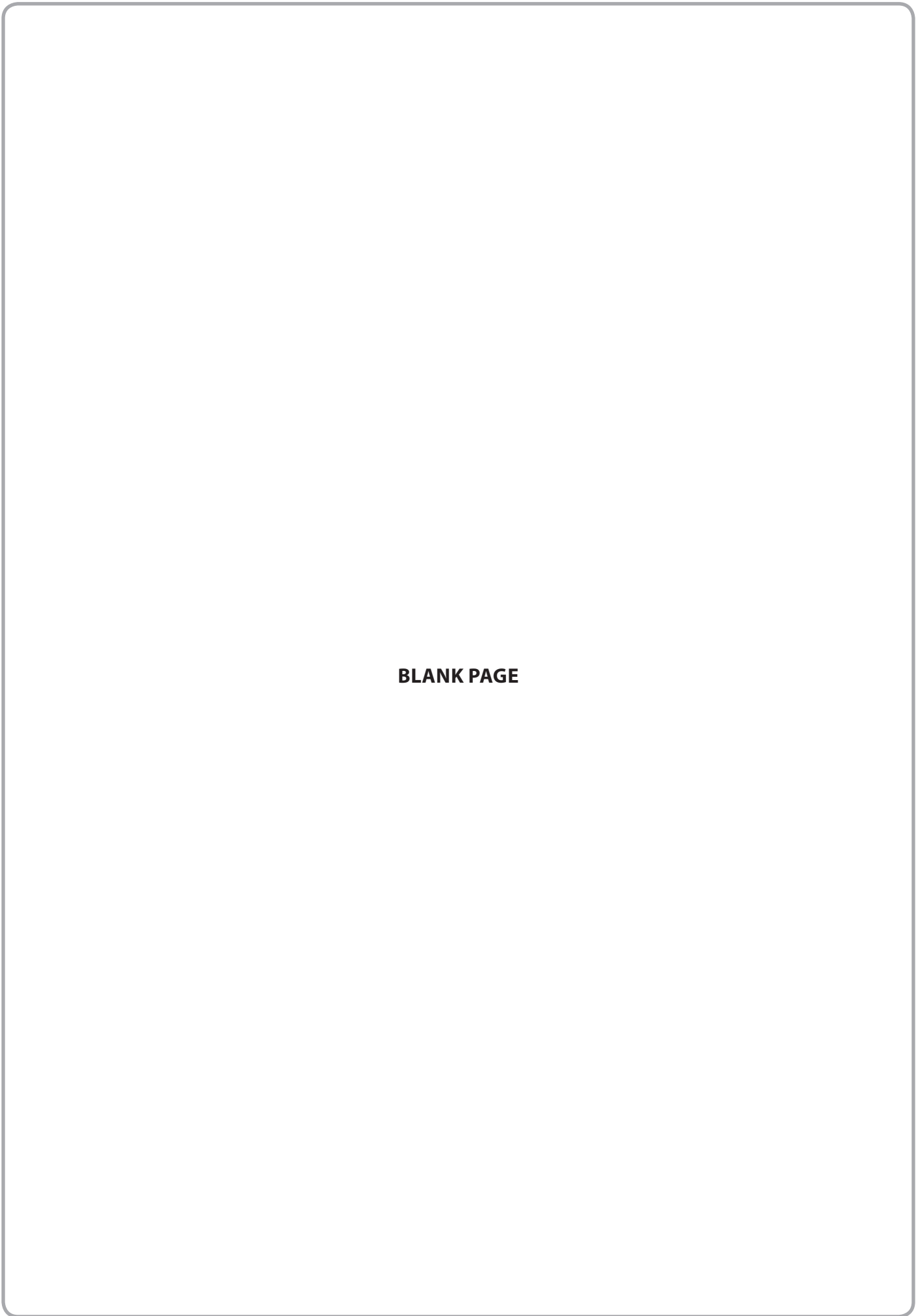

BLANK PAGE

DO NOT WRITE IN THIS AREA

DO NOT WRITE IN THIS AREA

DO NOT WRITE IN THIS AREA

DO NOT WRITE IN THIS AREA

DO NOT WRITE IN THIS AREA

DO NOT WRITE IN THIS AREA



- 6 (a) A student cut a piece of onion and placed it on a microscope slide.

The student then placed this slide on the stage of a light microscope and looked through the eyepiece.

No cells could be seen in the piece of onion.

Explain **two** ways this method could be improved to see details of the onion cells.

(4)

1.....

.....

.....

.....

2.....

.....

.....

.....



P 5 2 4 6 8 A 0 1 5 3 2

(b) Figure 7 shows mitosis occurring in some plant cells.

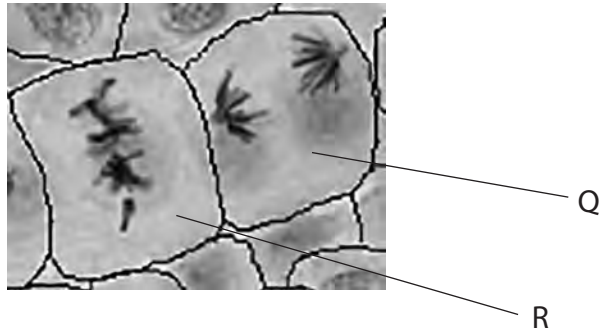

Figure 7

(i) The cells in Figure 7 were taken from a rapidly growing part of a plant.
Which part of a plant has rapidly dividing cells?

(1)

- A chloroplast
- B epithelium
- C meristem
- D vacuole

(ii) Which stage of mitosis is shown in cell R?

(1)

- A prophase
- B metaphase
- C anaphase
- D telophase

DO NOT WRITE IN THIS AREA

DO NOT WRITE IN THIS AREA

DO NOT WRITE IN THIS AREA

DO NOT WRITE IN THIS AREA

DO NOT WRITE IN THIS AREA

DO NOT WRITE IN THIS AREA



(iii) Describe **two** genetic similarities of the new cells that would be produced by cell Q in Figure 7.

(2)

1

2

(iv) The cells in Figure 7 were heated in hydrochloric acid.

State **two** safety precautions that should be taken when heating hydrochloric acid.

(2)

1

2

(c) Explain **one** advantage of using an electron microscope to observe plant cells.

(2)

.....

.....

.....

.....

(Total for Question 6 = 12 marks)



7 (a) The human population is increasing, so more food needs to be produced.

Farmers use fertilisers to increase the yield of wheat.

A farmer wants to find out the optimum concentration of fertiliser to use on his wheat plants.

He has a stock solution of concentrated fertiliser which is stated as 100%. He dilutes the stock solution to make 5%, 10%, 15% and 20% solutions.

He makes 100 cm³ of each solution.

(i) Describe how the farmer prepares 100 cm³ of the 20% solution.

(2)

.....
.....
.....
.....

(ii) The farmer has 60 wheat plants. Each plant is 20 mm in height.

Devise a plan to find the optimum percentage solution of fertiliser for the growth of these wheat plants.

(3)

.....
.....
.....
.....
.....
.....
.....
.....

DO NOT WRITE IN THIS AREA

DO NOT WRITE IN THIS AREA

DO NOT WRITE IN THIS AREA

DO NOT WRITE IN THIS AREA

DO NOT WRITE IN THIS AREA

DO NOT WRITE IN THIS AREA



8 (a) Cirrhosis is a disease caused by prolonged alcohol abuse.

(i) Prolonged alcohol abuse causes cirrhosis of the

(1)

- A brain
- B liver
- C heart
- D skin

(ii) Give **one** reason why cirrhosis is described as a non-communicable disease.

(1)

.....

.....

.....

(b) Obesity increases the risk of a person developing cardiovascular disease.

Losing weight can reduce the risk of this disease occurring.

Explain why exercise can cause weight loss.

(2)

.....

.....

.....

DO NOT WRITE IN THIS AREA

DO NOT WRITE IN THIS AREA

DO NOT WRITE IN THIS AREA

DO NOT WRITE IN THIS AREA

DO NOT WRITE IN THIS AREA

DO NOT WRITE IN THIS AREA



(c) Figure 8 shows a gastric band fitted to a stomach.

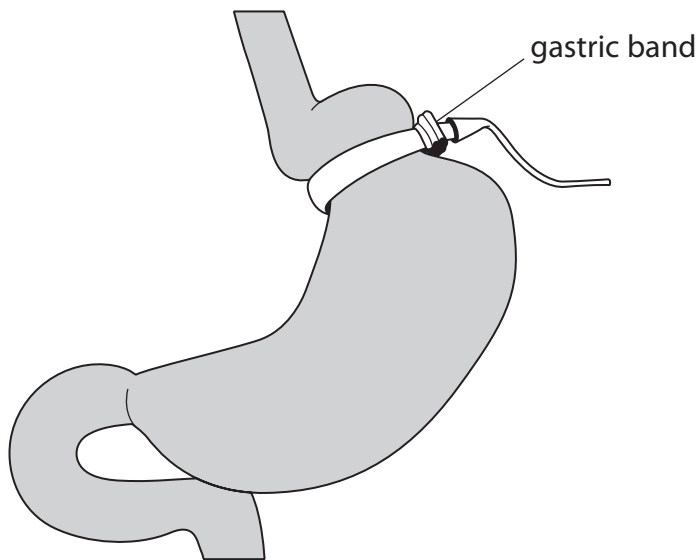

Figure 8

Explain how a gastric band helps a person to lose weight.

(2)

.....

.....

.....

.....

.....

DO NOT WRITE IN THIS AREA

DO NOT WRITE IN THIS AREA

DO NOT WRITE IN THIS AREA

DO NOT WRITE IN THIS AREA

DO NOT WRITE IN THIS AREA

DO NOT WRITE IN THIS AREA



(d) BMI and waist:hip ratio can be used to find out if a person is obese.

Figure 9 shows some data for two males.

male	BMI	waist:hip ratio
A	27.3	0.85
B	?	0.81

Figure 9

BMI is calculated using the equation:

$$\text{BMI} = \frac{\text{mass in kilograms}}{(\text{height in metres})^2}$$

(i) Male B has a mass of 72 kg and a height of 1.81 m.

Calculate the BMI of male B.

Give the answer to 3 significant figures.

(3)

BMI =

DO NOT WRITE IN THIS AREA

DO NOT WRITE IN THIS AREA

DO NOT WRITE IN THIS AREA

DO NOT WRITE IN THIS AREA

DO NOT WRITE IN THIS AREA

DO NOT WRITE IN THIS AREA



(ii) Figure 10 shows the interpretation of BMI values.

BMI range	interpretation
below 18.5	underweight
18.5 – 24.9	normal
25.0 – 29.9	overweight
30.0 and above	obese

Figure 10

Males with a waist:hip ratio above 0.90 are defined as abdominally obese.

Explain what the BMI and waist:hip ratio for male A shows about his weight distribution.

(2)

.....

.....

.....

.....

.....

(Total for Question 8 = 11 marks)



9 (a) Figure 11 shows two potato chips.

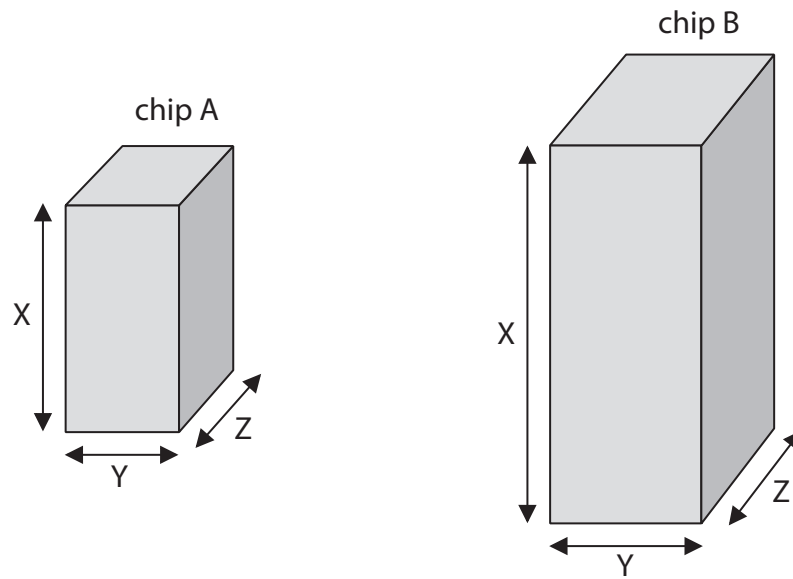

Figure 11

Figure 12 shows some information about each potato chip.

potato chip	length of X in cm	length of Y in cm	length of Z in cm	total surface area of four sides in cm ²	total surface area of top and bottom in cm ²	total surface area of chip in cm ²
A	3.0	1.5	1.5	18.0	4.5	22.5
B	5.0	2.0	2.0	?	?	?

Figure 12

(i) Calculate the total surface area of potato chip B using the formula,

$$\text{Total surface area} = 2XY + 2XZ + 2YZ$$

(2)

total surface area = cm²

DO NOT WRITE IN THIS AREA

DO NOT WRITE IN THIS AREA

DO NOT WRITE IN THIS AREA

DO NOT WRITE IN THIS AREA

DO NOT WRITE IN THIS AREA

DO NOT WRITE IN THIS AREA



- (ii) The potato chips were placed in distilled water for 20 minutes.

Figure 13 shows the increase in mass of each potato chip.

potato chip	increase in mass in grams
A	0.1
B	0.3

Figure 13

Explain why potato chip B has a greater increase in mass than potato chip A.

(2)

.....

.....

.....

.....

- (iii) Potato chip A is transferred from the distilled water into a concentrated salt solution.

Explain what will happen to the cells in potato chip A.

(3)

.....

.....

.....

.....

.....

.....



P 5 2 4 6 8 A 0 2 5 3 2

*(b) Figure 14 shows two varieties of potato plant.

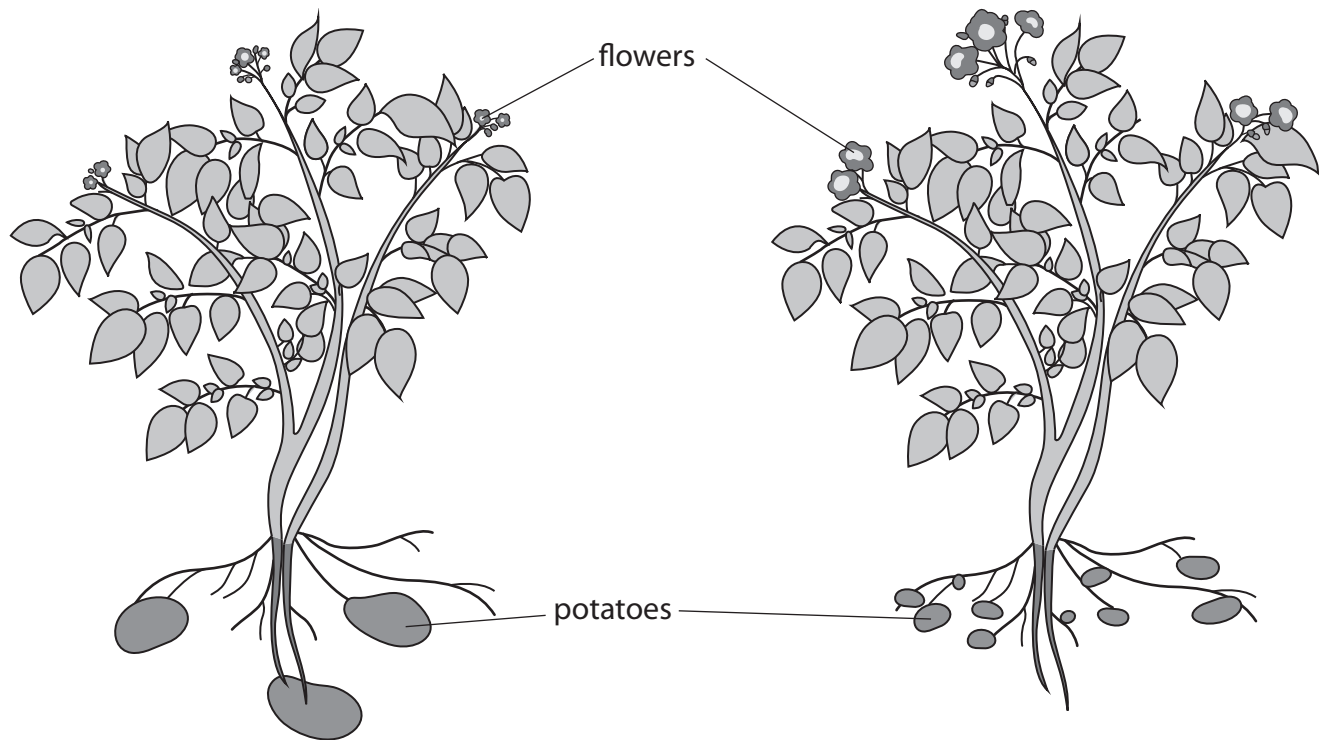

Variety A

- large potatoes
- few potatoes
- slow growing plant

Variety B

- small potatoes
- many potatoes
- fast growing plant

Figure 14

DO NOT WRITE IN THIS AREA

DO NOT WRITE IN THIS AREA

DO NOT WRITE IN THIS AREA

DO NOT WRITE IN THIS AREA

DO NOT WRITE IN THIS AREA

DO NOT WRITE IN THIS AREA



10 (a) Figure 15 shows a method of producing plants.

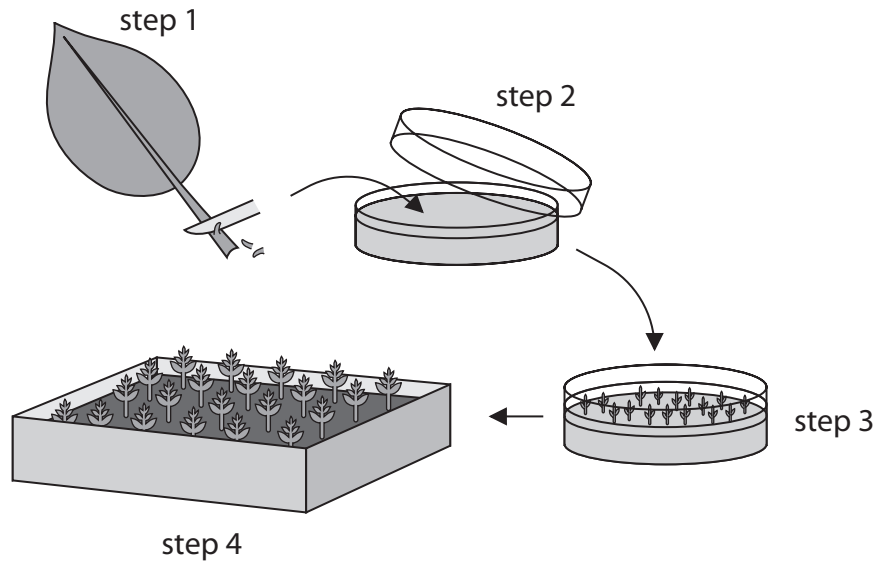

- Step 1. Cells taken from parent plant.
- Step 2. Cells placed on agar growth medium.
- Step 3. Cells develop into tiny plantlets.
- Step 4. Plantlets grown in compost.

Figure 15

(i) Some cells in each plantlet develop into root cells.

Name the process occurring as these cells develop into root cells.

(1)

(ii) Describe the advantages of producing plants by the method shown in Figure 15.

(2)

DO NOT WRITE IN THIS AREA

DO NOT WRITE IN THIS AREA

DO NOT WRITE IN THIS AREA

DO NOT WRITE IN THIS AREA

DO NOT WRITE IN THIS AREA

DO NOT WRITE IN THIS AREA



(iii) An autoclave is used to prepare the agar growth medium used in Step 2.

Explain why the agar growth medium is autoclaved.

(2)

.....

.....

.....

.....

.....

(iv) One of the plantlets had different coloured leaves.

Give **one** reason why this plantlet had different coloured leaves.

(1)

.....

.....

DO NOT WRITE IN THIS AREA

DO NOT WRITE IN THIS AREA

DO NOT WRITE IN THIS AREA

DO NOT WRITE IN THIS AREA

DO NOT WRITE IN THIS AREA

DO NOT WRITE IN THIS AREA



P 5 2 4 6 8 A 0 2 9 3 2

(b) Crop plants provide a source of energy in the form of carbohydrates such as starch and sugars.

(i) Describe the test to identify starch.

(2)

.....

.....

.....

.....

.....

DO NOT WRITE IN THIS AREA

DO NOT WRITE IN THIS AREA

DO NOT WRITE IN THIS AREA

DO NOT WRITE IN THIS AREA

DO NOT WRITE IN THIS AREA

DO NOT WRITE IN THIS AREA



- (ii) The amount of energy in the sugars extracted from crop plants can be measured using the calorimeter shown in Figure 16.

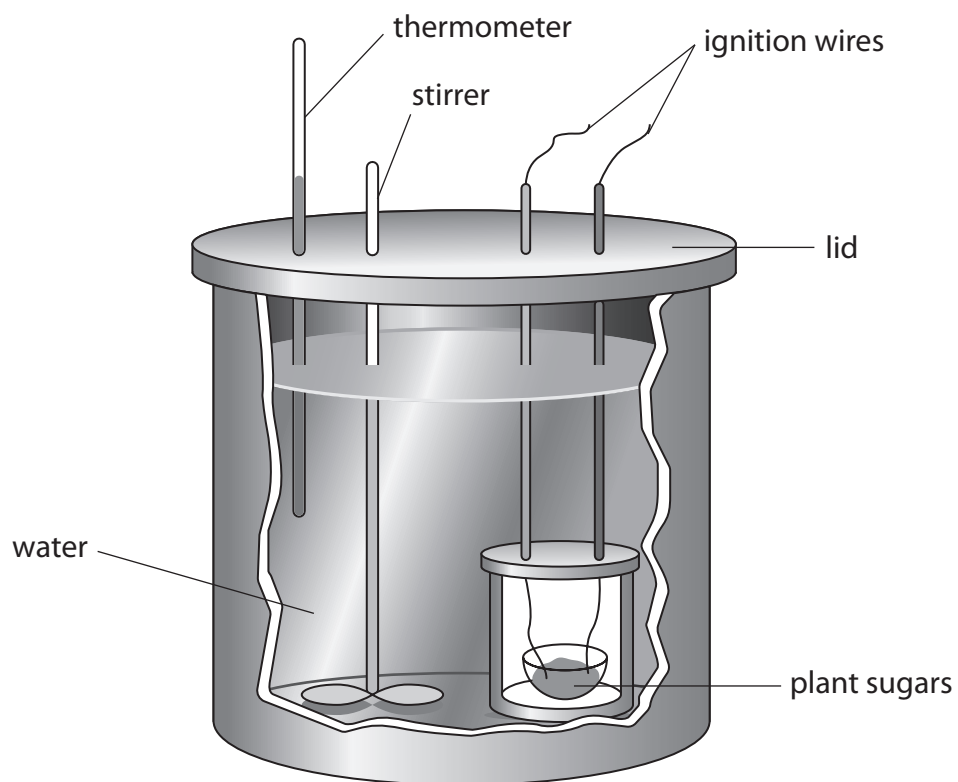

Figure 16

Explain why the calorimeter has a lid.

(2)

.....

.....

.....

.....

.....

(iii) State why it is important to stir the water in the calorimeter.

(1)

.....

.....

(Total for Question 10 = 11 marks)

TOTAL FOR PAPER = 100 MARKS

Every effort has been made to contact copyright holders to obtain their permission for the use of copyright material. Pearson Education Ltd. will, if notified, be happy to rectify any errors or omissions and include any such rectifications in future editions.





DO NOT WRITE IN THIS AREA

DO NOT WRITE IN THIS AREA

DO NOT WRITE IN THIS AREA

BLANK PAGE

